



877-639-2881

Vortec 5.7L V-8 Marine Engine

Replacement for MerCruiser, OMC, and Volvo. This new engine is available for the direct replacement of 1997 and newer Vortec 5.7L engines with a composite timing cover.

Features & Benefits

- High-flow cylinder head with straighter intake ports and a higher compression ratio delivers impressive horsepower
- Valvetrain features advanced design silent timing chain for added durability and positive inlet valve stem seals for reduced oil consumption
- Roller valve lifters for reduced friction and improved performance
- Composite front timing cover for noise reduction and corrosion protection
- Flywheels are offered with front-or-rear-mounted ring gears for various starter locations to suit inboard and stern drive applications
- Water pump is effective rotating in either a clockwise or counterclockwise direction
- Cylinder head gaskets have stainless steel core for corrosion resistance



The small block V-8 family of marine engines offers proven reliability and durability over a range of horsepower and torque.

Engine Details

- Displacement: 5.7L (350 CID)
- Horsepower: 292 HP @ 4800 RPM
- Torque: 370lb-ft @ 3200 RPM
- Accepts Mechanical Fuel Pump
- 8 Bolt Pattern Style for Intake
- 1 Piece Seal
- Opposite Rotation Available

Engine Includes

- Valve Covers
- Composite Timing Cover
- Oil Pan



MEFI-5 (Marine Electronic Fuel Injection-Fifth- Generation), is an advanced engine controller capable of meeting all the emissions, OBD-M and drivability requirements of marine applications.

Vortec 5.7L Feature Focus

We have taken expertise in designing outstanding Vortec truck and SUV engines and leverages it to make sophisticated yet extremely durable marine engines. In addition, the well-recognized Vortec brand name by itself has become a valuable selling tool for OEMs.



Many of our marine engines are Vortec engines. Vortec means uncompromised power - outstanding power with no sacrifice in fuel efficiency or durability and very little required maintenance.

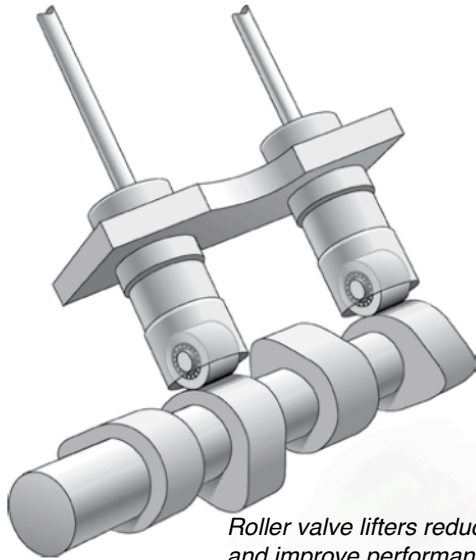

Roller valve lifters reduce friction and improve performance.

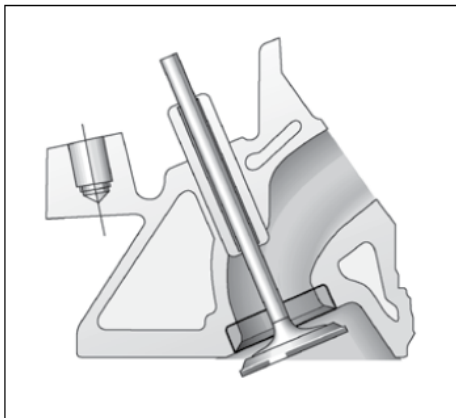

The exhaust valve seat inserts in the cylinder head provide superb durability.

Specifications

- Type:** 5.7L V-8 (Gen 1e Small Block)
- Displacement:** 350 cid (5736 cc)
- Engine Orientation:** Longitudinal
- Compression Ratio:** 9.4:1
- Valve Configuration:** Overhead Valves
(2 valves per cylinder)
- Valve Lifters:** Hydraulic Roller
- Fitting Order:** 1-8-4-3-6-5-7-2
- Bore x Stroke:** 101.60 x 88.39 mm
- Bore Center:** 111.76 mm
- Bore Area:** 648.59 cm²
- Fuel System:** Carb or Port Fuel Injection
with electronic throttle body unit (Optional)
- Fuel Type:** Regular Unleaded
- Horsepower:** 292 hp (218 kW) @ 4800 rpm
- Torque:** 370 lb-ft (502 Nm) @ 3200 rpm
Actual power levels may vary depending on OEM calibration and application.
- Fuel Shutoff:** MEFI-5 Yes
- Shipping Weight:** 432 lb (196 kg)
- Emissions Controls:** Positive Crankcase
Ventilation

Materials:

- Block: Cast Iron GM232-M
- Cylinder Head: Cast Iron
- Intake Manifold: Iron Lower
Aluminum Upper
- Exhaust Manifold: none
- Main Bearing Caps: Cast Iron GM232-M
- Crankshaft: Nodular Iron
- Camshaft: 5150 Steel Billet
- Connecting Rods: Forged- SAE 1141

Information may vary with application. All specifications listed are based on the latest product information available at the time of publication. The right is reserved to make changes at any time without notice.

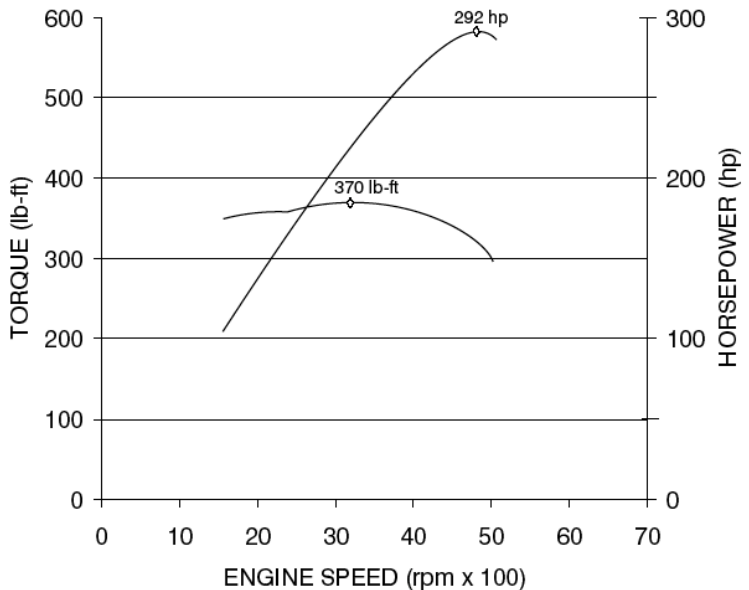

Actual power levels may vary depending on OEM calibration and application.

